

# Precision Power Analyzers Multi-Channel

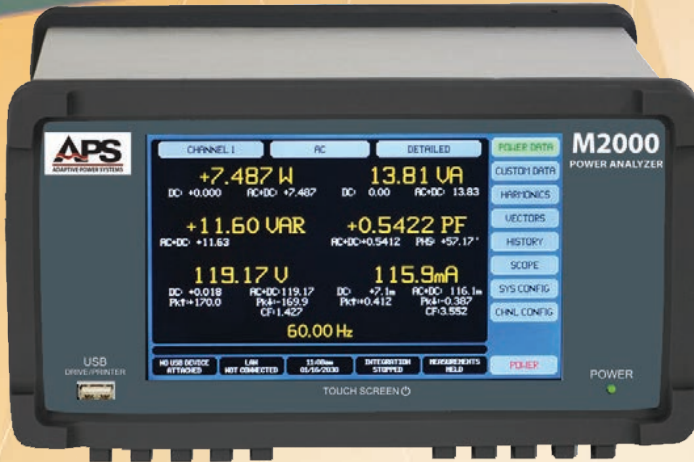

<b>M2000 Series</b>
<b>Four Card Slot Mainframe</b>
<b>1000 Vrms / <math>\pm 1750</math> Vpeak</b>
<b>Internal 20Arms Shunt (AD Card)</b>
<b>NEW Internal 30Arms Shunt (AH Card)</b>
<b>External Shunts or CTs (AX Card)</b>
<b>0.03% Base Accuracy Performance</b>

## Key Features and Benefits

- Affordable Accuracy, Bandwidth and Ease of Use
- Large Color Touch Screen Operation
- Multi-Channel Configurations
- Internal Shunt or External Current Transducer Channel Cards
- Extensive Measurement Functions to 1.25MHz:
  - Vac, Vdc, Vrms, Vac+dc, Iac, Idc, Irms, Iac+dc
  - Watts, VA, VAR, PF, CF
  - Voltage & Current Harmonics, Vthd, Ithd
- Multiple Virtual Power Analyzer Configurations
- Numeric and Graphical Displays
- Energy Star / IEC62301 Compliant Standby Power Measurement mode
- Ultra-quiet Fanless Operation
- Bench Use or 4U Height 19" Rack Mount

If you are in need of an accurate, yet easy to use precision Harmonic Power Analyzer, the M2000 Series is for you. Designed using state-of-the-art Digital Signal Processing, this modular power analyzer supports up four measurement cards using either internal or external current shunts. Each card has separate, fully synchronized, 24-bit high-speed data acquisition hardware that conditions and captures voltage and current input signals and processes data into a broad range of measurements.

Despite its breath of functions and features, the M2000 is simple to operate and provides an array of data display capabilities, taking full advantage of its high resolution color graphics display to present results in an optimal, easy to read and understand format.

For single-phase applications, the M2001 is all you need. For multi-phase power applications, the M2003 models support Delta and Wye AC power configurations to measure all phase voltages, currents and power.

## INDUSTRY LEADING DATA ACQUISITION TECHNOLOGY

The M2000 is an advanced power analyzer using cutting-edge data acquisition technology to accomplish unmatched accuracy at a greatly reduced cost.

The following technologies are deployed to achieve these results.

- Sampling Rate:** Real-time 245Ksps digital sampling rate is extended to an effective 384Msps sampling rate for periodic signal using a combination of deliberate signal jittering and repetitive sampling.
- Resolution:** 24 bits dual ADCs per channel
- Meas. Gap:** No inter-measurement gaps for 100% signal coverage of all non-harmonic measurements
- Synchronization:** Input signal synchronization to within  $< \pm 5$ ppm of an integer number of fundamental cycles
- Sampling Jitter:** Sampling is deliberately jittered such that the relative time of any given sample in a measurement period varies by up to  $\pm \frac{1}{2}$  a sample period but the net effect is zero when averaged over the entire measurement period. The jitter is quasi-random

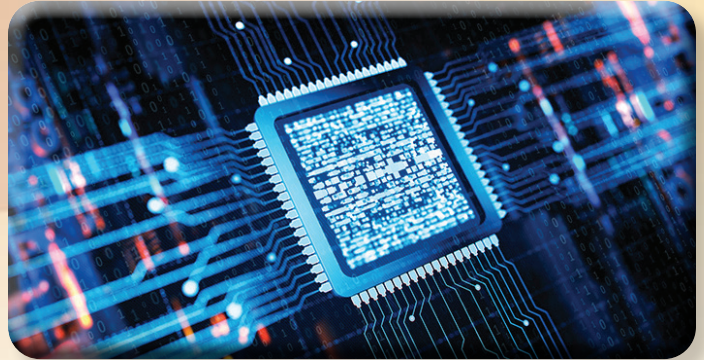

such that there are no sub-measurement period periodic elements within the actual sampling rate.

**Phase Accuracy:** The V and A inputs of each channel are sampled to ensure that the signals at the terminals are sampled nominally within  $< \pm 5$ ns of each other (equivalent of  $\pm 0.0018^\circ$  per kHz phase)

**Inter-Channel Diff:** All channels are sampled to ensure that all available input signals are sampled nominally within  $< \pm 20$ ns of each other (equivalent of  $\pm 0.0072^\circ$  per kHz phase)

## HARMONIC ANALYSIS

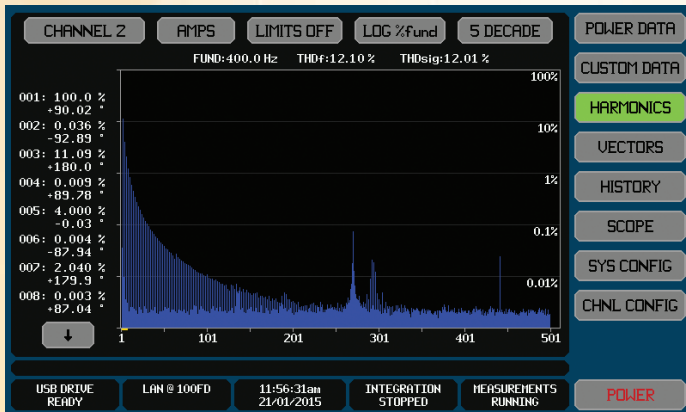

Current Harmonics Bar Chart Display

Harmonic Analysis is performed on each input of each channel configured to do so. There is no restriction on the number of channels configured for harmonic analysis other than max. available inputs (8). Up to 500 harmonics per channel can be analyzed.

The voltage and current samples are analyzed by means of DFT analysis performed with 48 bit precision and 64 bit accumulation. The DFT is modified from a standard sine/cosine transform by the use of modified sine and cosine tables to account for the jittered samples.

The voltage and current samples are sub-sampled and anti-alias filtered as needed. All harmonics of all inputs of all channels within a Virtual Power Analyzer are simultaneously analyzed to produce consistent multi-channel results.

## POWER MEASUREMENTS

The power data screen shown to the right is available using a single touch of the screen. It displays  $F_{\text{FUND}}$ , V, A, W, VA, VAR and PF data for any selected channel or group of channels. Up to three different channel groups can exist in a single M2000 unit.

In addition to the primary data, peak readings, phase, CF and other parameters are also available. Integrated data results like WHr can also be controlled and viewed from the power data screen.

For users with unique data requirements, custom data screens can be built with a spreadsheet application and downloaded to the M2000 via interface or USB drive.

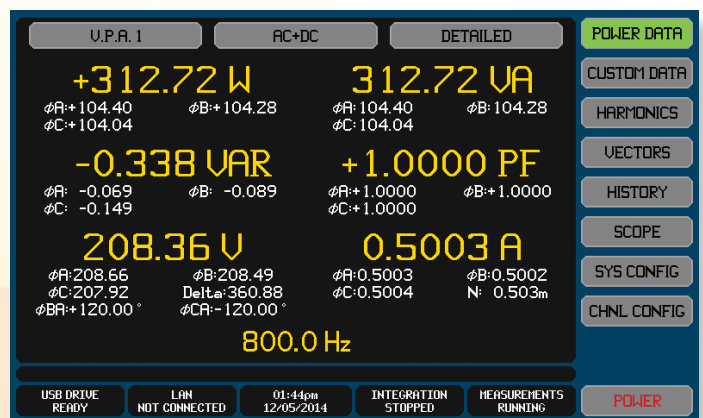

Power Measurement Data Display

## POWERFUL INFORMATION DISPLAYS IN FULL COLOR

### SCOPE VIEW MODE

The scope view display time domain information similar to a digital storage scope. Up to six signals can be displayed at once, each one having its own vertical scaling, offset and color. Common scope functions like timebase trigger level and trigger offset are user settable as well. The amplitude accuracy of the M2000 power analyzer far exceeds that of an actual digital storage scope so are unlikely to miss details you would not see on a scope.

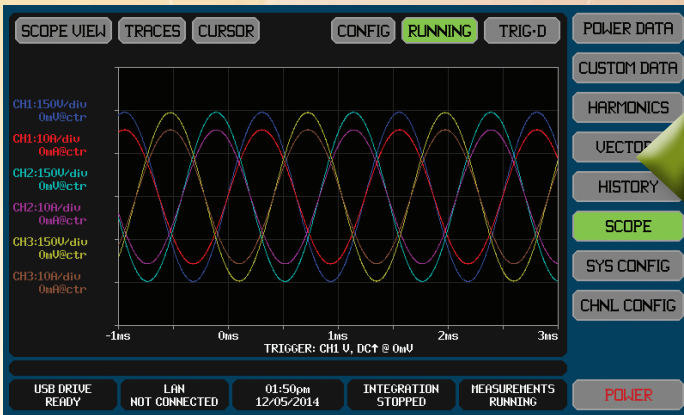

### CYCLE VIEW MODE

The cycle view display displays a single cycle of the voltage and current periodic waveforms, jitter sampled over multiple cycles within each measurement period providing time resolution down to 1/512<sup>th</sup> cycle or 2.6ns. The user can view the volts, amps and/or watts signals for any channel and/or inter-phase voltage signals for up to six traces, each with different vertical scaling and offsets.

This display mode is ideal for the inspection of periodic waveforms using extreme amplitude and time detail.



### VECTOR VIEW MODE

A polar chart graphically displays the fundamental voltage and current vectors for the selected channel or channel group. For multi-phase groups, the inter-phase voltages and non-measured neutral phase vectors are displayed. The user can enable the display of and select the color of each vector up to a maximum of 10.

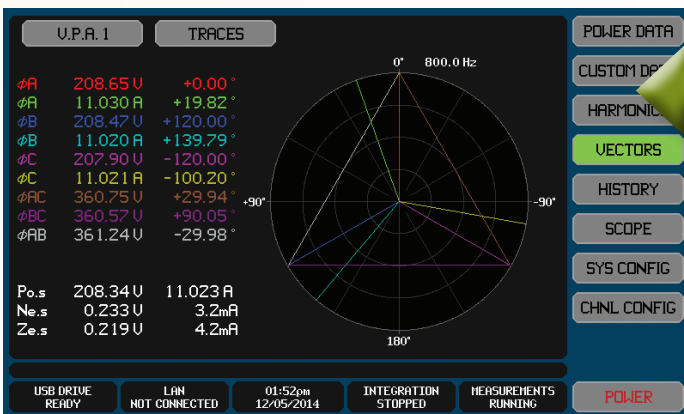

### STANDBY POWER VIEW MODE

The M2000 features built in standby power testing in accordance to EN50564:2011 (replaces IEC62301) which can be started by the pressing the STBY POWER screen touch key.

All information is nicely organized on a single screen for easy viewing and can just as easily be saved as an image file into a connected USB drive for inclusion into a report. Various measurement methods laid out in EN50564:2011, minimum test time, and data logging capability are all selectable. The M2000 also has the ability to perform multiple standby power measurements independently on each configured channel.

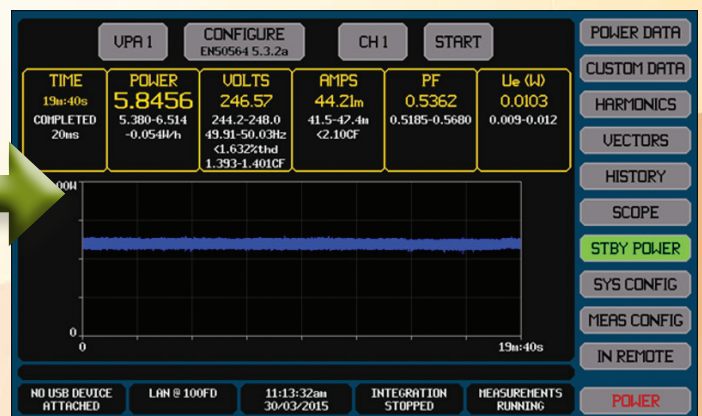

## CONVENIENT TOUCH SCREEN OPERATION

Front panel operation of the M2000 Power Analyzer is accomplished completely using its large touch-sensitive display. There are no buttons or dials to distract from the rich data displays provided to the user.

All signal connections are made at the back of the unit using color-coded, safety banana style jacks. Matching color alligator clip leads sets are included.



M2003 Chassis - Front Panel

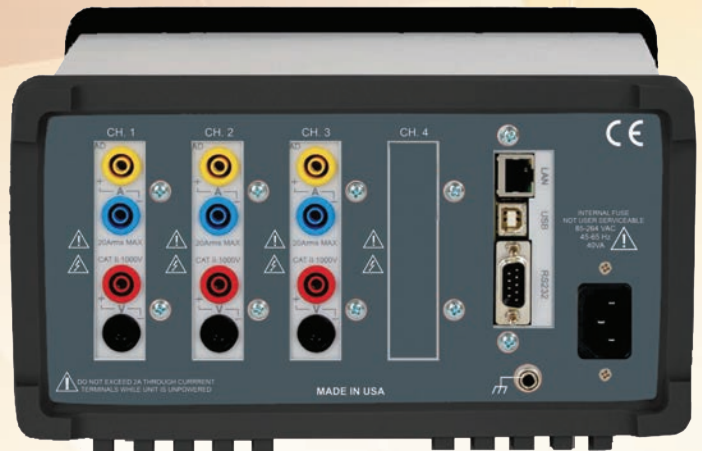

M2003 Chassis - Rear Panel

## CHANNEL CARD TYPES - AD, AH & AX

The M2000 Mainframe can accept one to four channel cards. Each channel card contains dual safety style input channels, one for Voltage and one for current. Two different card types are available for the M2000. The AD & AH Type cards use internal current shunts for all current measurements allowing currents up to 20Arms/150Apk or 30Arms/200Apk respectively.

The AX Type card uses external shunts or current transducers, allowing a wider range of currents to be supported. External current transformers or Hall Effect devices that produce a current output require the use of a burden resistor as the AX Type card measures voltage.

Cards can be mixed in the same M2000 Mainframe as needed. Both cards offer the same Base accuracy specification.



AD or AH Type Card (Left), AX Type Card (Right)

**Note:** Current shunts, transformers or transducers are not included with AX Type cards.

## AX CARDS - EXTERNAL SHUNTS OR CURRENT TRANSDUCERS

The external current shunt or current transducer input on AX Type cards will accept an input voltage up to 15Vrms / 20Vpk on the HI range. Depending on the V:A transducer used, a suitable burden resistor must be used to scale the voltage within this range. The V/A scaling can be configured on the power analyzer so current results are correctly displayed. When using an external current shunt, the LO range generally is the best choice.

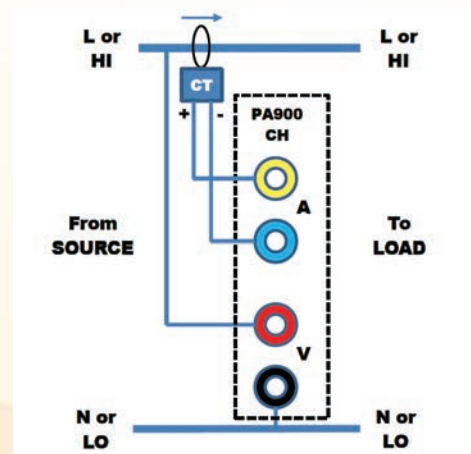

AX Type Card using external CT

# VIRTUAL POWER ANALYZER CONFIGURATIONS

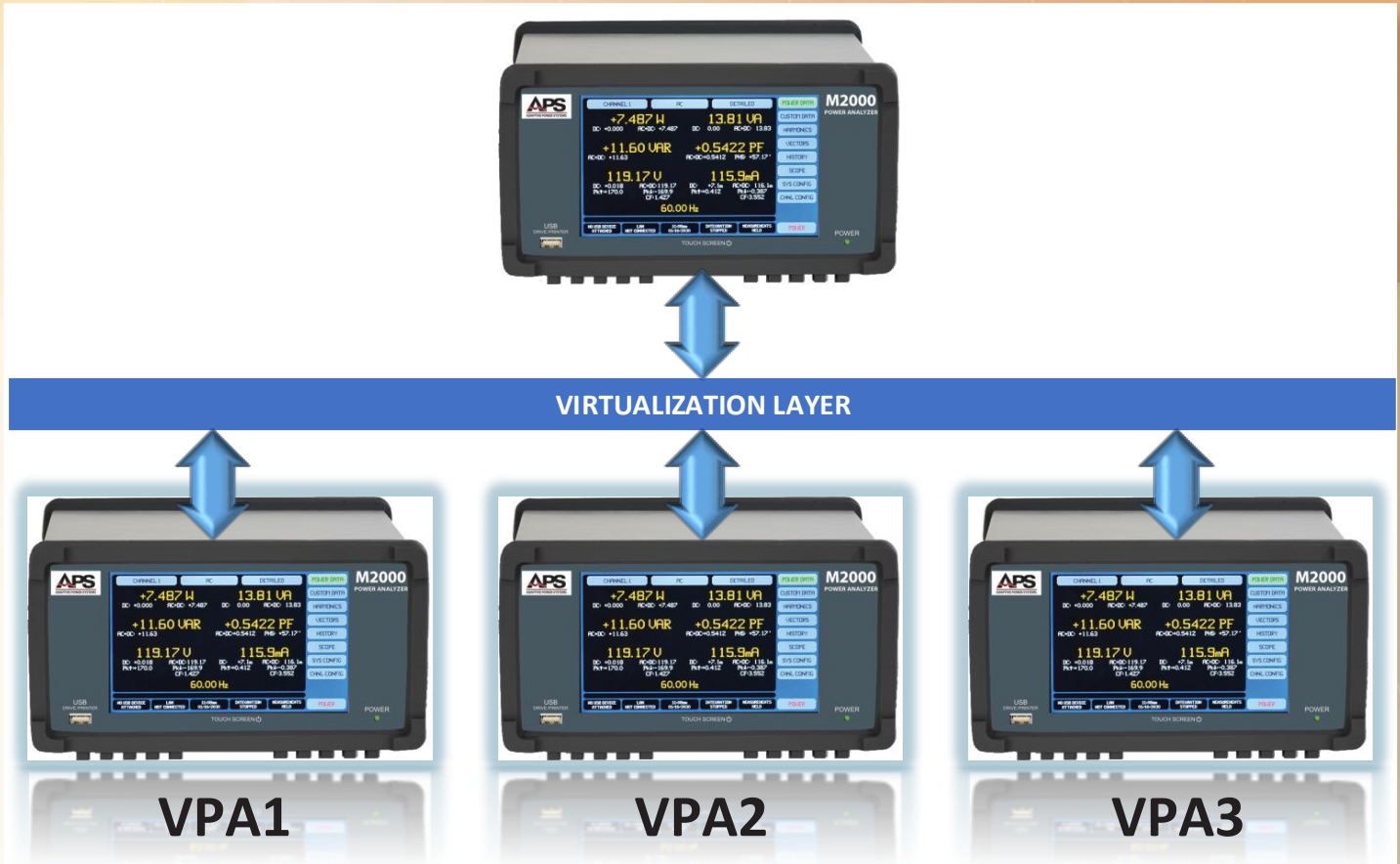

## Virtualization - Multiple Analyzers in One

The M2000 Series supports up to three virtual power analyzer configurations in a single mainframe, all sharing a single user interface. These are referred to as Virtual Power Analyzers or VPAs as illustrated above. Available channels may be configured in any one (or none) of these three VPAs. Each VPA may be configured to include anywhere from one up to all channels installed.

Each VPA is independently configured for multi-channel wiring configuration, signal filtering, default measurement coupling, display results smoothing, number of significant digits, VA/VAR combine method, and efficiency grouping.

Each virtual power analyzer may be configured as having one of the following synchronizations to the other virtual power analyzers:

- Totally asynchronous to the other virtual power analyzers in all aspects.
- Fully synchronous to another virtual power analyzer (identical sampling, measurement period and fundamental frequency).
- Totally asynchronous to the other virtual power analyzers but using the fundamental frequency established in another virtual power analyzer.

## Virtual Power Analyzer Wiring

Each VPA can be configured for the following multi-channel wiring configurations subject to the number of channels assigned to it:

- General (1 to 4 channels)
- 2 $\emptyset$ 3w (2 channels)
- 3 $\emptyset$ 3w (2 channels)
- 3 $\emptyset$ 3w (3 channels)
- 3 $\emptyset$ 4w (3 channels)

# VIRTUAL POWER ANALYZER APPLICATION EXAMPLES

## Virtualization Application Examples

Several application examples of using VPAs are shown for either one, two or three VPAs.

### SINGLE VPA APPLICATIONS

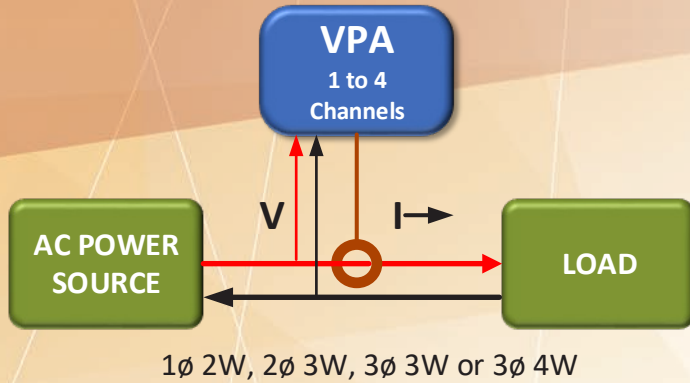

- Single phase, split phase and three phase AC products
- DC Power Supplies

### DUAL VPA APPLICATIONS

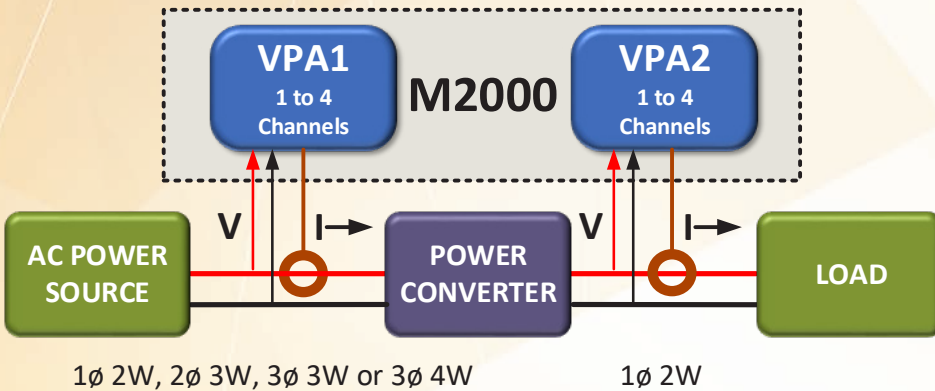

- AC to DC Power Supplies (single or multiple outputs)
- DC to DC Power Supplies (single or multiple outputs)
- Power Transformers (single or multi-phase)
- Lighting Ballasts (most types)
- Photovoltaic Power Generators (DC in; DC or AC out)

### TRIPLE VPA APPLICATIONS

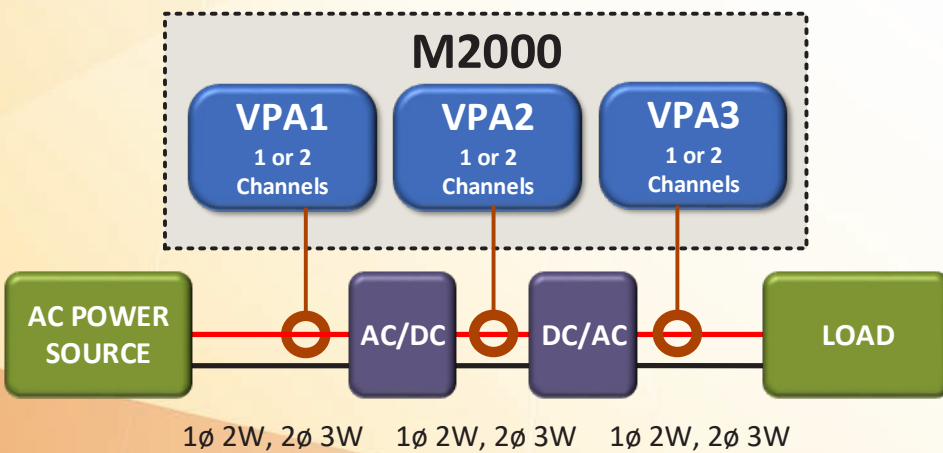

- Emergency Lighting Ballasts (most types)
- Standby or Backup Power Supplies (AC or DC)

## MAINS POWER APPLICATIONS

The vast majority of power measurements are made on commercial or industrial products that are powered from the Mains (Utility power). Since grid voltage and frequencies vary around the world and, even more importantly, power quality in some parts of the world can be problematic, testing products for world-wide power conditions is an important part of any quality control program.

The M2000 provides a wide range of functions and features to do just that and does so at a very economical cost, without sacrificing accuracy.

### EN50564 Standby Power Test

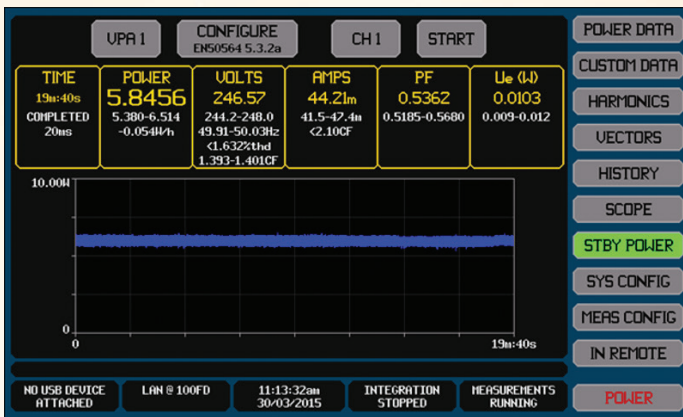

EN50564 Standby Power Measurement Screen

The EN 60564 International Standard covers Electrical and electronic household and office equipment - Measurement of low power consumption. It is similar to the IEC 62301, "Household electrical appliances - Measurement of standby power" standard and specifies how to measure standby power. This test requires a very low current range such as the 1 mA measurement range of the AD Channel card.

### Measurement Challenges

Standby power measurements can be challenging beyond requiring a very low current measurement range. Specifically, the following typical standby mode conditions present additional challenges for the power analyzer:

- Low power and current levels.
- Highly distorted current waveforms since power supplies operating at low load often draw very high crest-factor current.
- A low power factor because the current may be predominantly capacitive, through the power supply input's EMI filter.
- When a power supply is in burst mode, drawing power irregularly rather than continuously.

The M2000 has ample capability to meet these challenges as well as a dedicated Standby Power EN50546 test screen.

Any of the three available VPAs can be configured for single phase, split and/or three phase grid configurations. Selecting the MAINS frequency range configures all other relevant power analyzer settings for optimal performance on 50Hz to 60Hz voltage and current signals.

For use in ATE environments as part of functional test systems, the M2000 offers standard digital interfaces and available LabView instrument drivers for easy integration into any test stand.

### EN61000-3-2 & -3-12 Harmonics Emissions

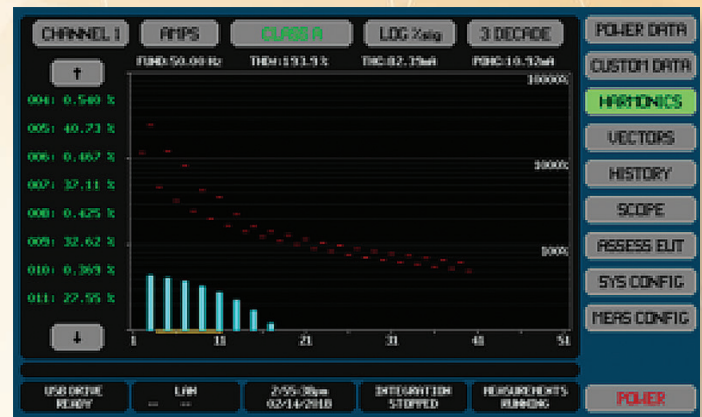

Products destined for Europe must meet Harmonics emissions limits as determined by harmonized standards IEC 61000-3-2 and IEC 61000-3-12. The M2000 can be used to check products during development for compliance so formal CE approval can be obtained more easily and less costly than finding problems later in the product development cycle. The M2000 offers special IEC test modes with settings and EUT class A, B, C and D harmonics limits to support these harmonics emissions measurements.



Home Appliance Test

## AVIONICS & DEFENSE POWER APPLICATIONS

The high bandwidth and accuracy of the M2000 Series supports a wide range of defense and avionics measurement applications for 400Hz fixed frequency or 360Hz to 800Hz wild frequency electrical equipment. Special measurement modes are provided for common avionics power compliance test standards such as RTCA DO-160, Section 16 or Boeing 787B3-0147.

Other standard M2000 functions like harmonics measurements, spectrum measurements, ripple measurements and distortion measurements can all be used during development, testing and certification of on-board electrical AC or DC equipment.

### MIL-STD 704 MEASUREMENTS



### RTCA DO-160 & BOEING 787B3 MEASUREMENTS



The M2000 is a perfect addition to any avionics power compliance test system utilizing a programmable AC power source for 400Hz or higher military AC power equipment certification. Its ability to measure up to 100 harmonics, even with a 400Hz or 800Hz fundamental power frequency, easily outperforms any programmable AC power source's measurement system.

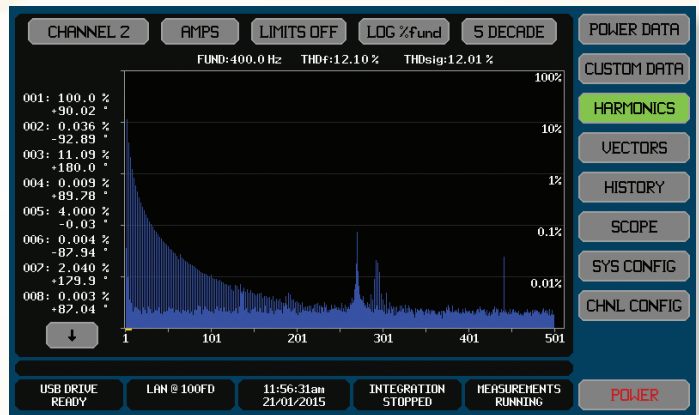

Current Harmonics Bar Chart Display

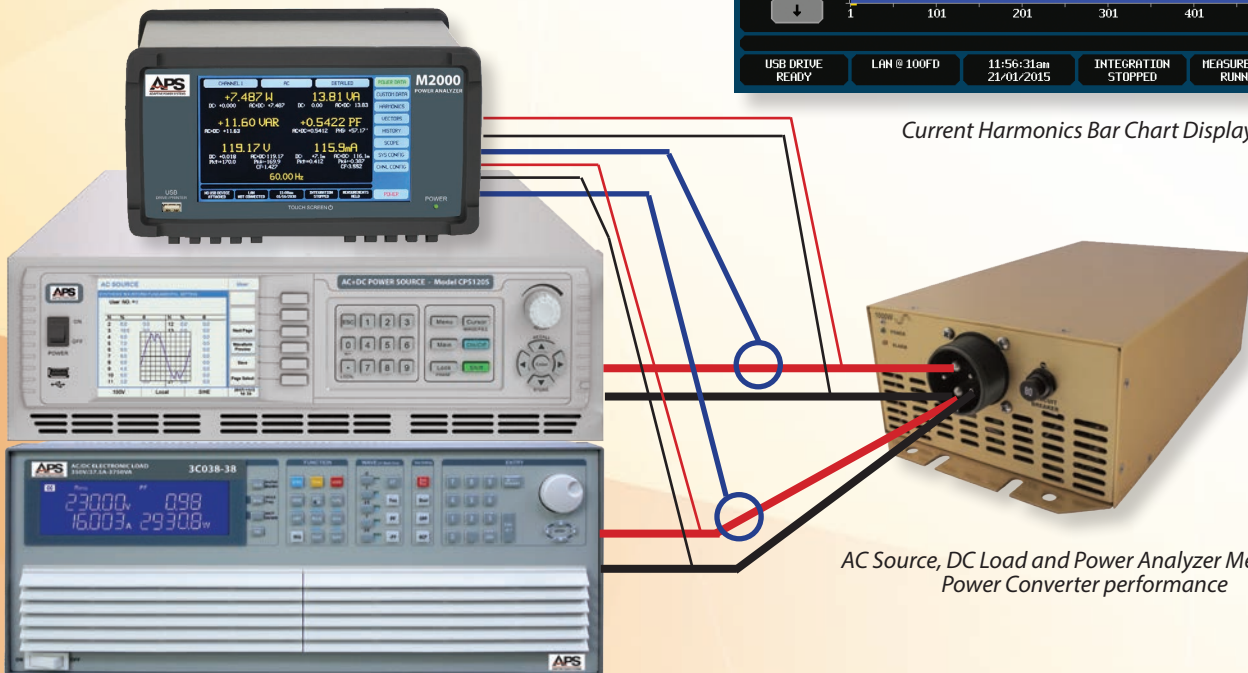

AC Source, DC Load and Power Analyzer Measuring Power Converter performance



## TECHNICAL SPECIFICATIONS

### Accuracy Specification Conditions

Accuracy specifications apply following a 10 minute warm-up period after turning power on in the unit. Accuracy specifications are valid for ambient tempera-

tures +/-5°C from calibration temperature. Add 0.005% reading/°C outside of +/-5°C from the calibration temperature. Accuracy specifications are valid for a period of two years after calibration in normal use.

PARAMETER	DESCRIPTION
<b>GENERAL SYSTEM</b>	
Display	7" TFT, 800 x 480 18 bpp Color LCD with high resolution pressure sensing touch
External Storage	Front panel USB Host
Sampling Rates	See Signal Sampling Specifications
Remote Control Interfaces	USB, RS232, LAN
No. of Channels	Up to four in any combination of AD and AX Cards

PARAMETER	DESCRIPTION
<b>AVAILABLE MEASUREMENTS</b>	
DC	Volts, Amps, Watts
AC (RMS)	Volts, Amps, Watts, VA, VAR, Power Factor, Effective Phase
AC+DC (RMS)	Volts, Amps, Watts, VA, VAR, Power Factor, Effective Phase
AC+DC (Rectified)	Volts, Amps
AC+DC (peak)	Volts (peak, high-pk and low-pk), Amps (peak, high-pk and low-pk)
AC+DC Crest Factor	Volts, Amps
AC+DC Form Factor	Volts, Amps
Inter-phase	Volts
Neutral	Amps
Load	Impedance (DC, AC and AC+DC), AC series resistance and inductance, AC parallel resistance and capacitance

PARAMETER	TYPE	RANGE
<b>VOLTAGE INPUT RANGES</b>		
Specified Input Range	DC	< 1000 Vdc
	AC	< 1000 Vrms
	Peak	< 1750 Vpk
No Damage Input Range	< 1 ms	3000 Vrms
	< 100 ms	2000 Vrms
	< 5 secs	1500 Vrms
	Continuous	1000 Vrms
Measurable Voltage	< 1830 Vrms and Vpk	
Impedance Burden	1.201 MΩ ± 0.25 %	
Bandwidth (-3dB)	900 kHz Typical	

PARAMETER	CONDITION	AD CARD / AH CARD		AX CARD	
		HI Range	LO Range	HI Range	LO Range
<b>CURRENT INPUT RANGES</b>					
Measurable Current Range		< 150 Arms / Apk	< 1.02 Arms / Apk	< 23.1 Vrms / Vpk	< 0.576 Vrms / Vpk
Specified Current Range	AD: AH:	< 20 Arms / < 140 Apk < 30 Arms / < 200 Apk	< 1 Arms / Apk	< 15 Vrms / < 20Vpk	< 0.55 Vrms / Vpk
No Damage Input Range	< 8 ms	< 150 Arms / < 250 Apk	< 60 Arms / < 150Apk	< 200 Vrms / < 300Vpk	< 20 Vrms / < 30 Vpk
	< 40 ms	< 50 Arms	< 40 Arms	< 50 Vrms	< 10 Vrms
	< 1 secs	< 30 Arms	< 5 Arms	< 30 Vrms	< 20 Vrms
	Continuous	< 20 Arms	< 2 Arms	< 25 Vrms / Vpk	< 5 Vrms / Vpk
	Power OFF	< 2 Arms / < 150 Apk		< 25 Vrms / < 300 Apk	
Impedance		4 mΩ to 12 mΩ	0.562 Ω ±0.75%	20.5 kΩ ±0.25%	10.25 kΩ ±0.25%
Bandwidth (-3dB)		1.25 MHz		1.25 MHz	

PARAMETER	DESCRIPTION	
<b>VOLTAGE MEASUREMENT PRIMARY ACCURACY</b>		
<b>Maximum Scaling Errors</b>		
Overall Accuracy	Add relevant errors from the table below for the maximum error in primary voltage measurements (e.g. DC, AC, AC+DC, Rectified, Peak, Valley, Peak-Valley).	
Resolution	0.1 mV	
Base Accuracy	0.03 % Rdg	
Frequency Dependent	0.01Hz - 1Hz	0.01 % Rdg
	400Hz	0.005% Rdg
	< 10kHz	F * 0.005% Rdg
	10Hz - 40kHz	0.05%+(F -10)*0.012% Rdg
	40Hz - 100kHz	0.41%+(F -40)*0.025% Rdg
100kHz - 1Mhz	$(F_{kHz}/1000)^2 * 100\%$	
Self Heating	Only significant at higher voltages	$0.05\% * (V_{AC+DC}/1000)^2$
Temperature	0.005% per °C outside of ±5°C from cal. temp.	
Bandwidth Limit	Applies to USER BW setting only	$10\% * (F / F_{BW})^2$ (unspecified for $F > 0.3 * F_{BW}$ )
<b>Maximum Floor Errors</b>		
Base Floor Error	450 μV Apply to all results as shown below in Volts (generally only significant at low input levels)	
DC Floor Error	1 mV	
AC Floor Error	MAINS, <10kHz	100 μV/Vrdg
	400Hz, <50kHz	300 μV/Vrdg
	Otherwise	1.1 mV/Vrdg
AC Peak Error	MAINS, <10kHz	40 mV
	400Hz, <50kHz	75 mV
	Otherwise	125 mV
Common Mode Err	1 μV per V x Hz	
Adjacent Chn Err	300 nV per V x Hz	

## TECHNICAL SPECIFICATIONS (Continued)

PARAMETER	CONDITION	AD CARD / AH CARD		AX CARD	
CURRENT MEASUREMENT PRIMARY ACCURACY		HI Range	LO Range	HI Range	LO Range
<b>Maximum Scaling Errors</b>					
	Add relevant errors from the table below for the maximum error in primary current measurements (e.g. DC, AC, AC+DC, Rectified, Peak, Valley, Peak-Valley).				
Base Scaling Error				0.03 % Rdg	
Frequency Dependent Scaling Error	LF, VLF			0.01% Rdg	
	400Hz			0.002% Rdg	
	< 10kHz			F * 0.003% Rdg	
	10k-40kHz			0.03% + (F - 10) * 0.007% Rdg	
	40k-100kHz			0.24% + (F - 40) * 0.02%	
	100k-1Mhz			(F/1250) <sup>2</sup> * 100%	
	> 1Mhz	0.24% + (F-100) * 0.012% (Typical)		0.3% + (F - 100) * 0.015% (Typical)	
Self-Heating Scaling Error		0.0002% * A <sub>AC+DC</sub> <sup>2</sup>		None	
Temperature Scaling Error		0.005% per C outside of ±5° C from calibration temperature			
<b>Maximum Floor Errors</b>					
	Apply to all results as shown below in Amps (generally only significant at low input levels)				
Base Floor Error		38 µA	250 nA	6 µV	150 nV
DC Floor Error		0.15 mA	1 µA	40 µV	5 µV
AC Floor Error	MAINS, LF, VLF, <10kHz	1.5 µA / A Rdg	90 pA / A Rdg	35 nV / V Rdg	20 pV / V Rdg
	400Hz, <50kHz	15 µA / A Rdg	0.9 nA / A Rdg	350 nV / V Rdg	200 pV / V Rdg
	Otherwise	150 µA / A Rdg	9 0A / A Rdg	3.5 µV / V Rdg	2 nV / V Rdg
Peak Floor Error	MAINS, LF, VLF, <10kHz	5 mA / A Rdg	40 µA / A Rdg	0.75 mV / V Rdg	25 µV / V Rdg
	400Hz, <50kHz	17 mA / A Rdg	125 µA / A Rdg	2.5 mV / V Rdg	65 µV / V Rdg
	Otherwise	50 mA / A Rdg	400 µA / A Rdg	7.5 mV / V Rdg	200 µV / V Rdg
Common Mode Error		400pA per V*Hz	20pA per V*Hz	15nV per V*Hz	0.5nV per V*Hz
Adjacent Channel Error		120pA per V*Hz	7pA per V*Hz	7nV per V*Hz	0.2nV per V*Hz

PARAMETER	CONDITION	AD CARD / AH CARD		AX CARD	
WATT, VAR & VA MEASUREMENT ACCURACY		HI Range	LO Range	HI Range	LO Range
<b>Maximum Scaling Errors</b>					
	Apply to all results as shown below as a percentage of the reading If signal contains significant levels at multiple frequencies, apply to each level & frequency				
Base Scaling Error				0.045 % Rdg	
Frequency Dependent Scaling Error	LF, VLF			0.01% Rdg	
	400Hz			0.005% Rdg	
	< 10kHz			F * 0.006% Rdg	
	10k-40kHz			0.06% + (F - 10) * 0.014% Rdg	
	40k-100kHz			0.48% + (F - 40) * 0.032%	
	100k-1Mhz			(F/1100) <sup>2</sup> * 150% (Typical)	
	> 1Mhz	(F/5000) * 150% (Typical)		(F/3000) * 150% (Typical)	
Self-Heating Scaling Error		Add Voltage and Current Self-Heating Errors			
Temperature Scaling Error		0.005% per C outside of ±5° C from calibration temperature			
BW Limit Scaling Error		20% * (F / F <sub>BW</sub> ) <sup>2</sup> , unspecified above 0.3 * F <sub>BW</sub>			
<b>Maximum Floor Errors</b>					
	Apply to all results as shown below in Watts, VA or VAR as applicable (generally only significant at low input levels)				
Base Floor Error		(V <sub>AC+DC</sub> * 38µA) + (A <sub>AC+DC</sub> * 450µV)	(V <sub>AC+DC</sub> * 250nA) + (A <sub>AC+DC</sub> * 450µV)	(V <sub>AC+DC</sub> * 6µA) + (A <sub>AC+DC</sub> * 450µV)	(V <sub>AC+DC</sub> * 0.15µA) + (A <sub>AC+DC</sub> * 450µV)
DC Floor Error	DC	(V <sub>DC</sub> * Current DC Floor Error) + (A <sub>DC</sub> * Voltage DC Floor Error) + (Current DC Floor Error * Voltage DC Floor Error)			
AC Floor Error	VA, VAR	(V <sub>AC</sub> * Current AC Floor Error) + (A <sub>AC</sub> * Voltage AC Floor Error)			
Common Mode Error	VA, VAR	(V <sub>AC</sub> * Current Common Mode Error) + (A <sub>AC</sub> * Voltage Common Mode Error)			
	Watts	(A <sub>AC</sub> * Voltage Common Mode Error)			
Adjacent Channel Error		(V <sub>AC</sub> * Current Adjacent Channel Error) + (A <sub>AC</sub> * Voltage Adjacent Channel Error)			
Phase Floor Error	VAR	V <sub>AFUND</sub> * (1 - PF <sub>FUND</sub> - cos(cos <sup>-1</sup> (1-PF <sub>FUND</sub> ) + 0.015° * F))			
	Watts	V <sub>AFUND</sub> * (PF <sub>FUND</sub> - cos(cos <sup>-1</sup> (PF <sub>FUND</sub> ) + 0.015° * F))			

## TECHNICAL SPECIFICATIONS (Continued)

PARAMETER	CONDITION	AD CARD / AH CARD		AX CARD	
HARMONIC WATT MEASUREMENT ACCURACY		HI Range	LO Range	HI Range	LO Range
Harmonics or Spectrum Watt Error	AC Watts Errors other than Phase Floor Error from preceding table at levels and F of the harmonic or spectrum point + (H/N) <sup>2</sup> * 0.5% of reading + from below using the frequency of the harmonic or spectrum point				
	< 10kHz	0.006% + (0.004% + 0.028% * F) / PF			
	10k-115kHz	0.05% + (0.004% + 0.028% * F) / PF			

PARAMETER	CONDITION	AD CARD / AH CARD		AX CARD	
POWER FACTOR (PF) MEASUREMENT ACCURACY		HI Range	LO Range	HI Range	LO Range
Add relevant errors from the table below for the maximum error in PF measurements. For PF <sub>FUND</sub> apply only the Base Floor and Phase Errors. Applies to AC, AC+DC and FUND PF results					
Base Floor Error	Applies to all PF results	(38µA / A <sub>AC+DC</sub> ) + (450µV / V <sub>AC+DC</sub> )	(250nA / A <sub>AC+DC</sub> ) + (450µV / V <sub>AC+DC</sub> )	(6µA / A <sub>AC+DC</sub> ) + (450µV / V <sub>AC+DC</sub> )	(0.15µA / A <sub>AC+DC</sub> ) + (450µV / V <sub>AC+DC</sub> )
AC Floor Error		-PF Rdg * ((Current AC Floor Error/A Rdg) + (Voltage AC Floor Error / V Rdg))			
DC Floor Error	Applies to AC+DC PF result after multiplying by (1-PF)	(150µA / A <sub>AC+DC</sub> ) + (1mV / V <sub>AC+DC</sub> )	(1µA / A <sub>AC+DC</sub> ) + (1mV / V <sub>AC+DC</sub> )	(40µA / A <sub>AC+DC</sub> ) + (1mV / V <sub>AC+DC</sub> )	(5µA / A <sub>AC+DC</sub> ) + (1mV / V <sub>AC+DC</sub> )
Phase Error	Applies to all PF results	(PF <sub>FUND</sub> - cos(cos <sup>-1</sup> (PF <sub>FUND</sub> ) ± 0.015° * F)) Alternately, as a worst case (at PF=0) this can expressed as F * 0.00028			

PARAMETER	DESCRIPTION	
<b>FREQUENCY MEASUREMENTS</b>		
Ranges	MAINS	45 Hz to 65 Hz
	AVIONICS	300 Hz to 900 Hz
	VLF	0.0099 Hz - 65 Hz
	LF	0.19 Hz - 1000 Hz
	All other	9 Hz - 80 kHz
Min. DC Input Level (Typ.)	Voltage	0.5Vrms
	Current AD	HI : 0.04 Arms LO: 0.3 mArms
	Current AX	HI: 5 mVrms LO: 150 µVrms
Min. Pulse Width (Typ.)	5 µsec, 0.001% of Meas Period, 10% of Signal Period	
Resolution (Nominal)	0.0005% / Update period	
Max. Error	0.01% + Resolution	

PARAMETER	DESCRIPTION
<b>REMOTE CONTROL INTERFACES</b>	
-USB	USB 2.0 Serial Interface
Connector	USB Type-B, Rear Panel
-LAN	Ethernet 10BaseT / 100BaseTX
Connector	RJ45 , Rear Panel
Protocols	ICMPv4, ARP, UDP/IPv4, TCP/IPv4, DCHPv4, mDNS, IGMPv3
Port	10733
-RS232	RS232 Serial Interface
Connector	DB9 Male , Rear Panel
Baud Rates	9600, 19200, 57600, 115200 bps
Formats	Data, Parity, Stop Bits: 8,N,1

PARAMETER	DESCRIPTION
<b>AC MAINS INPUT</b>	
AC Input Voltage	85 ~ 264Vac ±10%, 1 Phase
Input Frequency	50Hz ~ 60Hz ±5Hz
Power Consumption	40 VA max.
Installation Category	CAT II

PARAMETER	DESCRIPTION
<b>SAFETY &amp; ENVIRONMENTAL</b>	
Measurement Categories	EN61010-1 CAT I 1000V; EN61010-1 CAT II 1000V; CAT III 600V; CAT 300V
Environment	Pollution Degree 2
Operating Temperature	0° C ~ +40°C / +32°F ~ +104°F
Storage Temperature	-20° C ~ +75°C / -4°F ~ +167°F
Max. Relative Humidity	< 85% RH, non-condensing
Max. Operating Altitude	2000 meters / 6562 feet ASL

PARAMETER	DESCRIPTION
<b>DIMENSIONS &amp; WEIGHT</b>	
Size (H x W x D) (Height with feet not extended)	137 x 248 x 284mm 5.4" x 9.75" x 11.2"
Shipping Size	229 x 356 x 356 9" x 14" x 14"
Net Weight	3.2 Kg / 7.0 lbs
Shipping Weight	5.4 Kg / 12 lbs

## ORDERING INFORMATION

### Standard Models

Select standard pre-configured M2000 Power Analyzer model from table below. Custom configurations available with potentially longer delivery times. M2000 Mainframe can hold from one through max. four channel cards of different types as needed. Card may be added at a later time on existing units through customer service.

MODEL	DESCRIPTION	NO CHANNELS	CARD TYPE
M2000	Digital Power Analyzer Mainframe Only	None	N/A
M2001D	Digital Power Analyzer, Single Channel, AD Card - Internal 20A Shunt	1	AD
M2001H	Digital Power Analyzer, Single Channel, AH Card - Internal 30A Shunt	1	AH
M2001X	Digital Power Analyzer, Single Channel, AX Card - External Transducer	1	AX
M2003D	Digital Power Analyzer, Three Channels, AD Cards - Internal 20A Shunts	3	AD
M2003H	Digital Power Analyzer, Three Channels, AH Cards - Internal 30A Shunts	3	AH
M2003X	Digital Power Analyzer, Three Channels, AX Cards - External Transducers	3	AX
Other	Contact Factory for other channel configurations	Max. = 4	AD, AH and/or AX

### Measurement Card Types

CARD TYPE	DESCRIPTION	NO CHANNELS
AD	AD Type Channel Card with Dual Current Shunt Input. Includes 4 color coded, heavy duty 1.5 meter test leads and a NIST cal cert (no data). Max. Current 20 Arms.	2 - Voltage, Current
AH	AH Type Channel Card with Dual Current Shunt Input. Includes 4 color coded, heavy duty 1.5 meter test leads and a NIST cal cert (no data). Max. Current 30 Arms.	2 - Voltage, Current
AX	AX Type Channel Card with External Current Transducer Input. Includes 4 color coded, heavy duty 1.5 meter test leads and a NIST cal cert (no data).	2 - Voltage, Current Transducer Voltage

MODEL	DESCRIPTION
M2000-RMK	19" Rack mount kit for one M2000 Chassis, 4U / 7" Rack height

### Accessories



Color Coded Alligator Lead Set per Card



US AC Line Cord



M2000-RMK Rack Mount Kit

## SERVICE AND SUPPORT

Adaptive Power Systems' customer support is second to none. Our Customer Support Program provides the training, repair, calibration, and technical support services that our customers value. So, in addition to receiving the right test equipment, our customers can also count on excellent support before, during and after the sale. With company owned support and service centers around the world, support is never far away.

**New Product Warranty:** Two (2) years.

Complete calibration and repair services are offered at our US, European and Chinese manufacturing facilities (see contact info below). Calibrations are to original factory specifications and are traceable to NIST (National Institute of Standards and Technology).

### NORTH & SOUTH AMERICA

PPST Solutions, Inc.  
Irvine, USA  
Phone: +1(888) 239-1619  
Email: [sales@ppstsolutions.com](mailto:sales@ppstsolutions.com)

### EUROPE

Caltest Instruments GmbH.  
Kappelrodeck, Germany  
Phone: +49(0)7842-99722-00  
Email: [info@caltest.de](mailto:info@caltest.de)

### CHINA

PPST Shanghai Co. Ltd.  
Shanghai, China  
Phone: +86-21-6763-9223  
Email: [info@ppst.com.cn](mailto:info@ppst.com.cn)



### PPST Solutions, Inc. Sales Department

17711 Mitchell North, Irvine CA 92614  
Direct: 888-239-1619 • Fax: 949-756-0838  
Email: [info@ppstsolutions.com](mailto:info@ppstsolutions.com)  
[www.adaptivepower.com](http://www.adaptivepower.com)    [www.ppstsolutions.com](http://www.ppstsolutions.com)

